

**DC - 6.0 GHz.
HYBR-FILM**

**Model: TNF250-50 Type N Female
TSF250-50 SMA Female
TSM250-50 SMA Male**



HYBR-FILM™ Coaxial terminations are the highest performing RF & Microwave power film resistive products on the market today. Designed for bolt-down conduction cooled, directly to a heat-sink offers high power and higher frequency ratings than other suppliers. Power ratings from 30 - 1500 watts CW combined with versatile industry standard configurations allow for easy design-in solutions or replacing older outdated marginal devices that may have degraded or drifted over time. Applications include Medical, Broadcast, Industrial, Commercial Wireless, Military and Space. The **P3** variety of designs allows for modifications of standard designs to be made quickly and inexpensively to meet specific requirements with short delivery times. Please contact the factory for any special requirements or frequency ranges and power levels.

Electrical Performance		Mechanical Specification	
Frequency:	DC - 6.0 GHz.	Resistor:	Hybrid Blended Thick Film
Impedance:	50Ω ±2% (Standard)	Chip Material:	99.6% Beryllium Oxide
Power:	250 Watts Average	Housing:	Aluminum 6061-T6 Alloy
VSWR:	<1.35 Typ. 1.5 Max.DC-6.0 GHz.	I/O :	N Female, SMA Female, SMA Male
Power Rating:	100% @ +100°C	Finish:	Nickel Plate per QQN-290
		Operating Temp.:	-55°C to +150°C

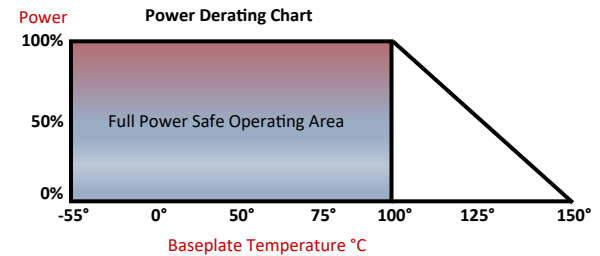

Specifications subject to change without notice

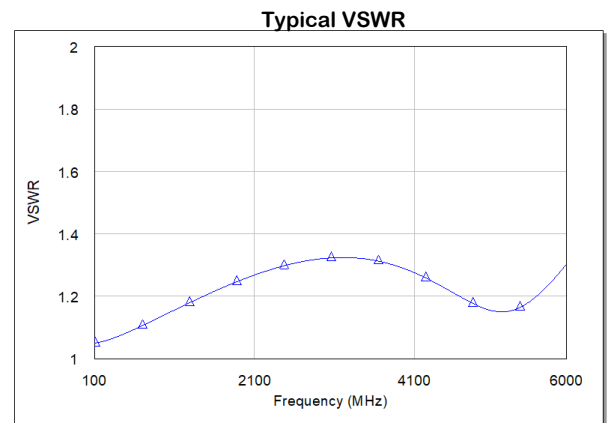
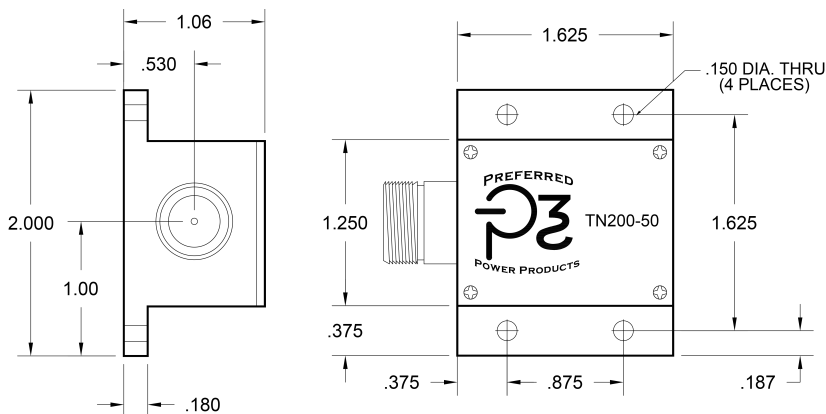

For more information Contact Sales: sales@p3-rf.com